

MSL FlipLock d-check

FlipLock e-check Seite 2

Anschlussschema

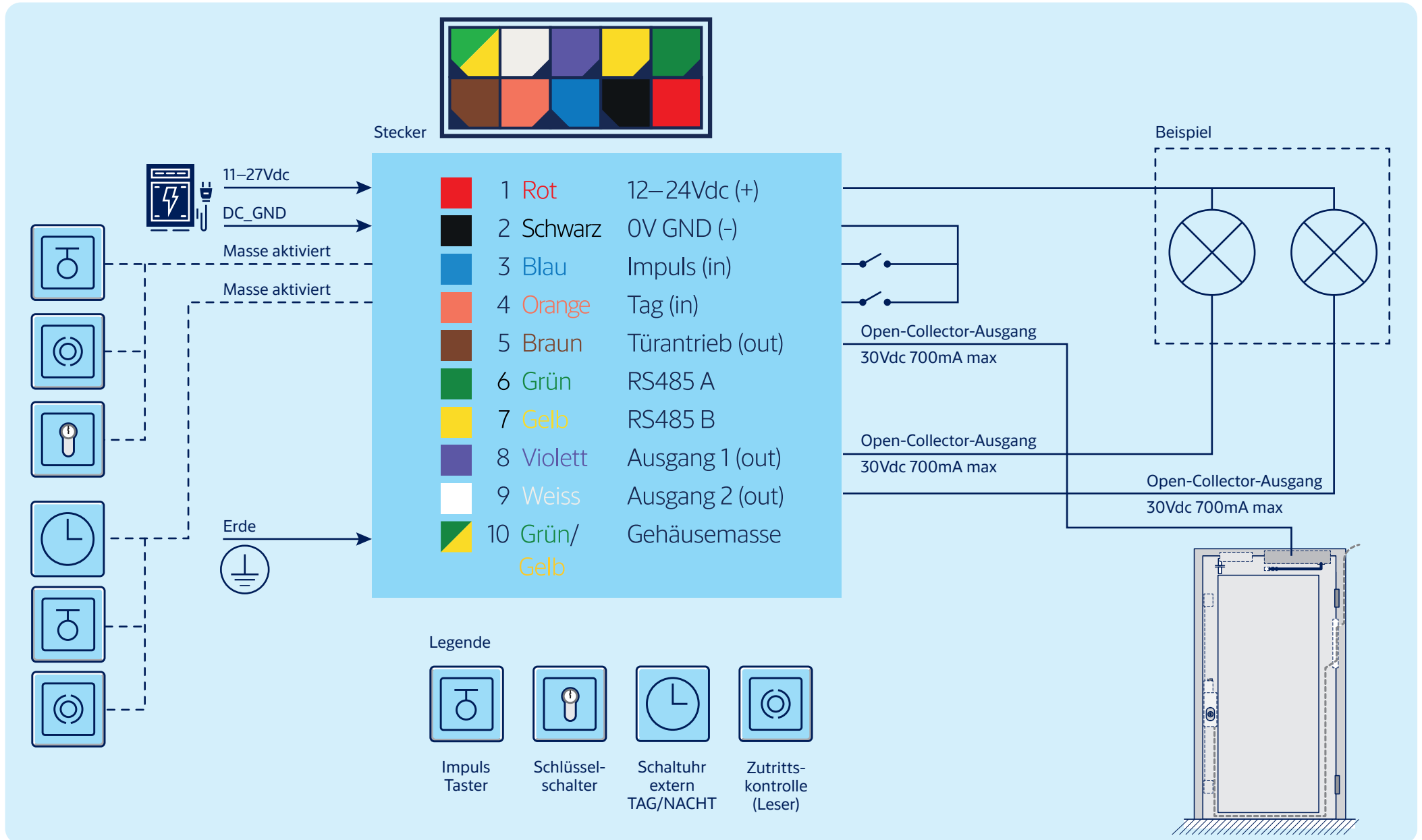

MSL FlipLock e-check

Anschlussschema

FlipLock d-check Seite 1

