

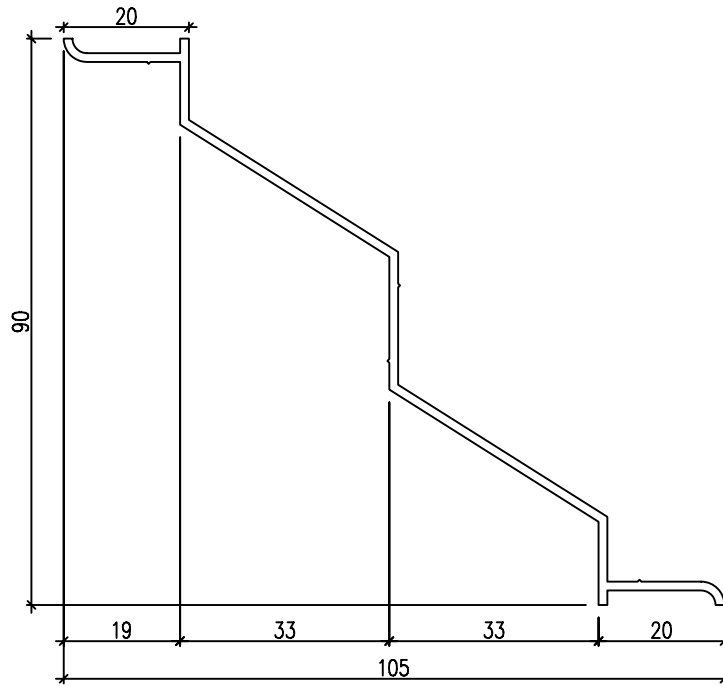

Draufsicht  
(Maßstab 0,85:1)

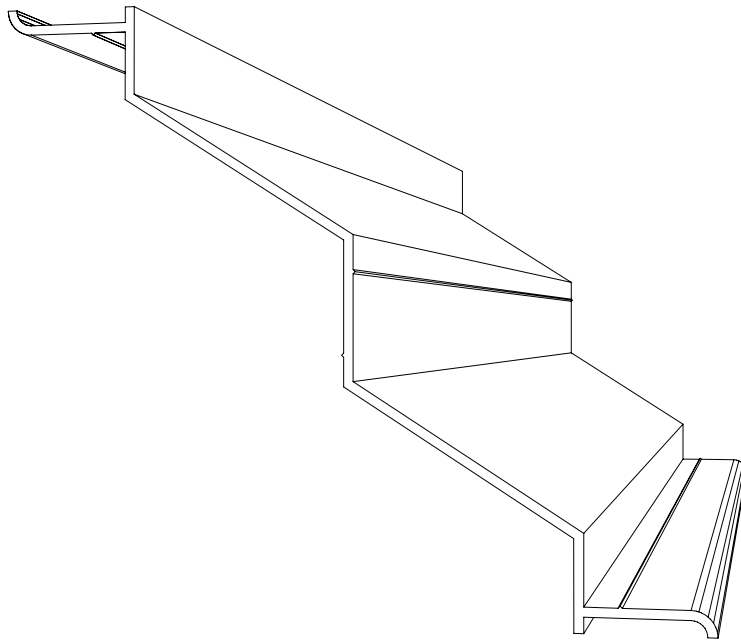

ISO-Ansicht



|               |            |       |      |   |  |             |  |   |  |               |  |
|---------------|------------|-------|------|---|--|-------------|--|---|--|---------------|--|
| Auftrags-Nr.: |            |       |      | Maßangaben in mm  |  | Norm        |  | Maßstab: 0,85 : 1                                 |  | Gewicht:      |  |
|               |            |       |      |   |  |             |  | Werkstoff: Aluminium                              |  | Modellnummer: |  |
|               |            |       |      |   |  |             |  | Zeichnungs-Nr.:                                   |  | Index: 0      |  |
|               |            |       |      | Datum   |  | Name        |  | Benennung / Bezeichnung:<br><b>sonal H10Z</b>     |  |               |  |
|               |            |       |      | Gezeichnet  |  |             |  |   |  |               |  |
|               |            |       |      | Kontrolliert  |  |             |  |   |  |               |  |
|               |            |       |      | Freigabe  |  |             |  |   |  |               |  |
|               |            |       |      | Konstruiert durch:  |  | Linke       |  | Internet: www.mll-gmbh.de e-mail: mll@mll-gmbh.de |  | Blatt:        |  |
|               |            |       |      | <b>MLL GmbH</b><br>Liebigstr. 26<br>22113 Hamburg<br>Tel:040-736-79 40-0 Fax:040-736-79 40-29 |  |             |  |   |  | A4            |  |
| Status        | Änderungen | Datum | Name | Ursprung:   |  | Ersatz für: |  | Ersetzt durch:                                    |  |               |  |

