

Ⓓ Technische Information: Kantriegel

ⒼⒷ Technical information: Flush bolt

WSS

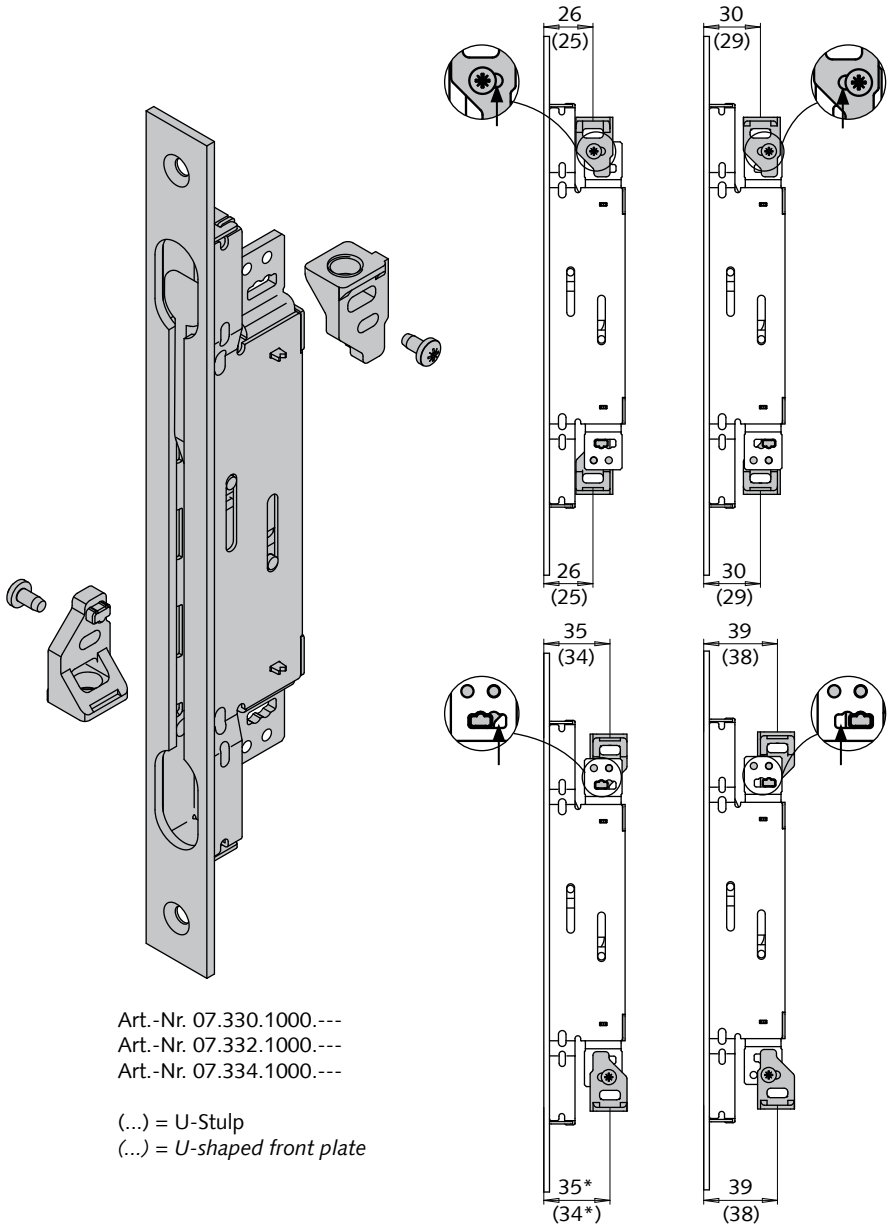

Art.-Nr. 07.330.1000.---
Art.-Nr. 07.332.1000.---
Art.-Nr. 07.334.1000.---

(...) = U-Stulp
(...) = U-shaped front plate

* vormontiertes Dornmaß
pre-assembled backset

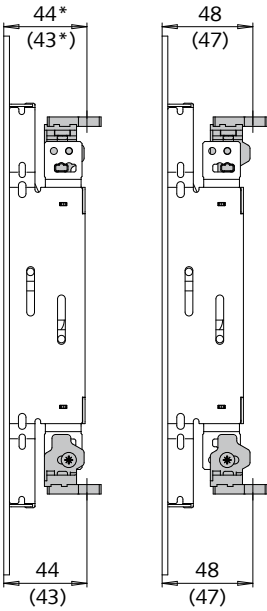

Art.-Nr. 07.330.2000.---
 Art.-Nr. 07.332.2000.---
 Art.-Nr. 07.334.2000.---

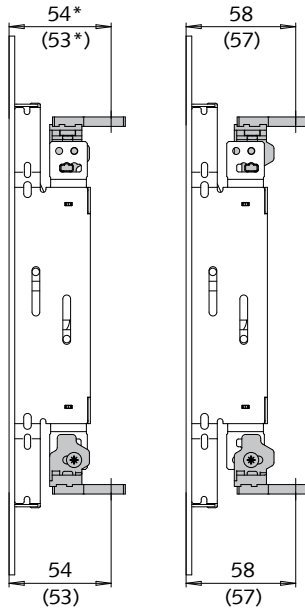

Art.-Nr. 07.330.3000.---
 Art.-Nr. 07.332.3000.---
 Art.-Nr. 07.334.2000.---

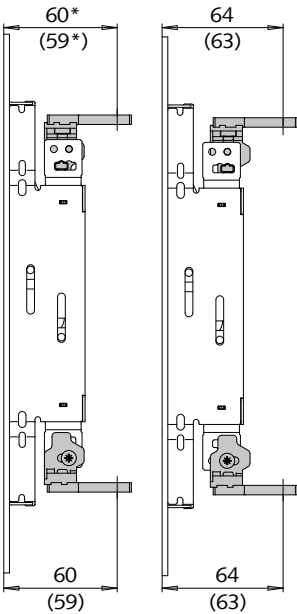

Art.-Nr. 07.330.4000.---
 Art.-Nr. 07.332.4000.---
 Art.-Nr. 07.334.2000.---

* vormontiertes Dornmaß
pre-assembled backset

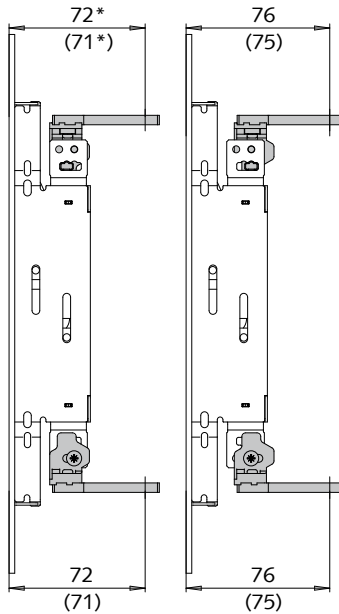

Art.-Nr. 07.330.5000.---
 Art.-Nr. 07.332.5000.---
 Art.-Nr. 07.334.2000.---

(...) = U-Stulp
 (...) = *U-shaped front plate*

WSS

Wilh. Schlehtendahl & Söhne
 GmbH & Co. KG

Hauptstraße 18-32
 42579 Heiligenhaus
 Deutschland

Tel.: +49 (0) 20 56/17-0
 Fax: +49 (0) 20 56/51 42

wss@wss.de
 www.wss.de