

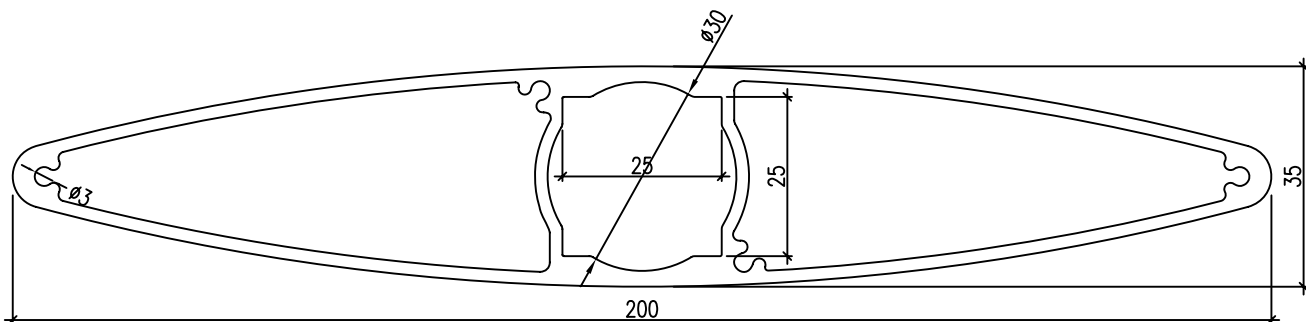

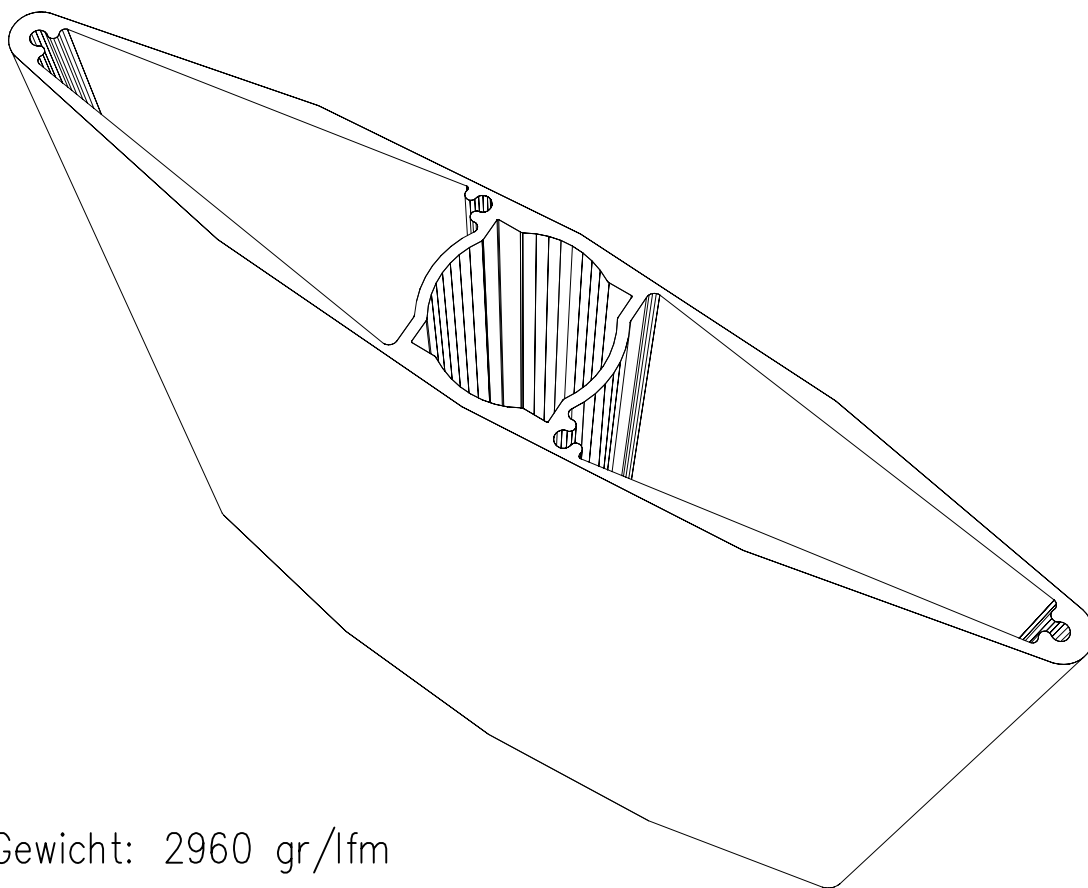

Draufsicht  
(Maßstab 0,85:1)



ISO-Ansicht



Theor. Gewicht: 2960 gr/lfm

Auftrags-Nr.:				Maßangaben in mm		Norm		Maßstab: 0,85 : 1		Gewicht:	
								Werkstoff: Aluminium		Modellnummer:	
								Zeichnungs-Nr.:		Index: 0	
				Datum	Name		<b>Benennung / Bezeichnung:</b> <b>sonal D-200</b>  <b>Blatt:</b>				
				Gezeichnet							
				Kontrolliert							
				Freigabe							
				Konstruiert durch:	Devtecs		Internet: www.mll-gmbh.de		e-mail: mll@mll-gmbh.de		
				<b>MLL GmbH</b> Liebigstr. 26 22113 Hamburg Tel:040-736-79 40-0 Fax:040-736-79 40-29							
Status	Änderungen	Datum	Name	Ursprung:		Ersatz für:		Ersetzt durch:			

