

SCALA 0.300

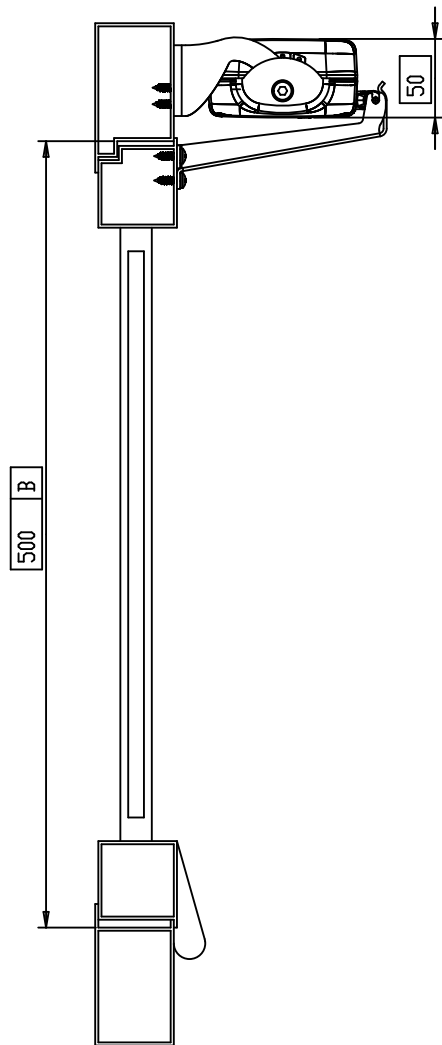

SELEZIONE CORSE  
STROKES SELECTOR

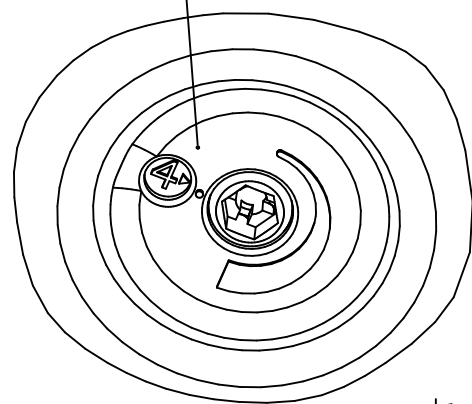

SCALA 2.000

SCALA 1.500

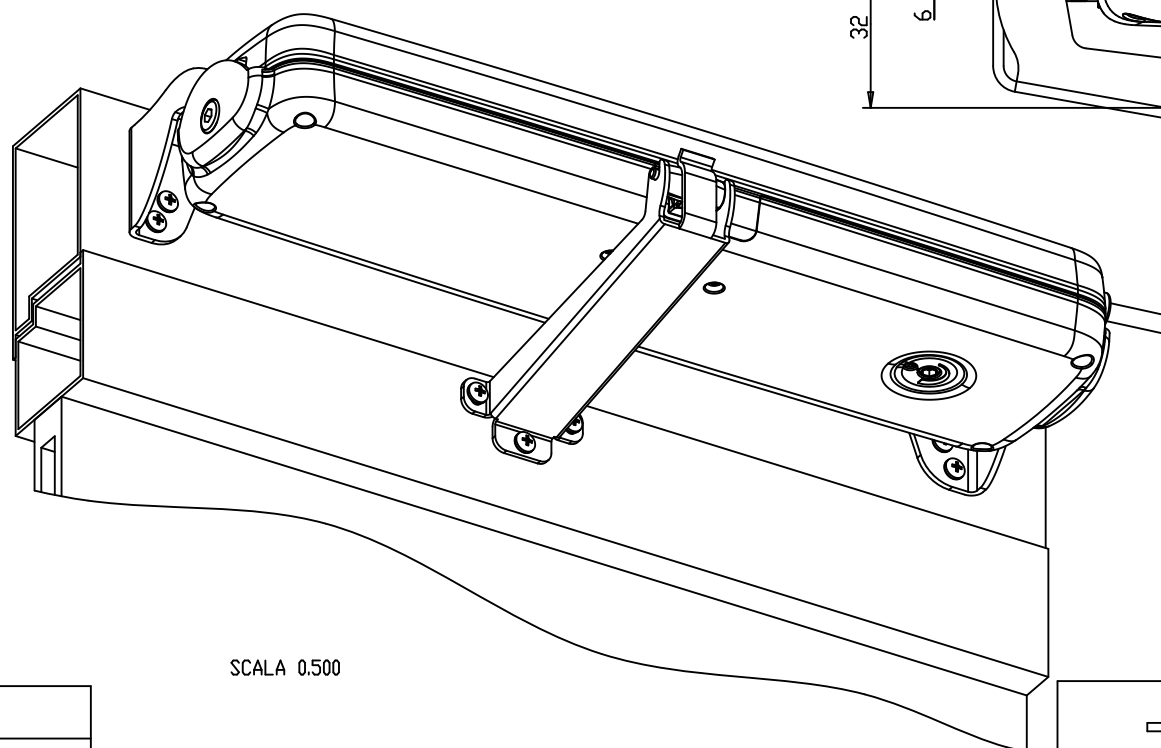
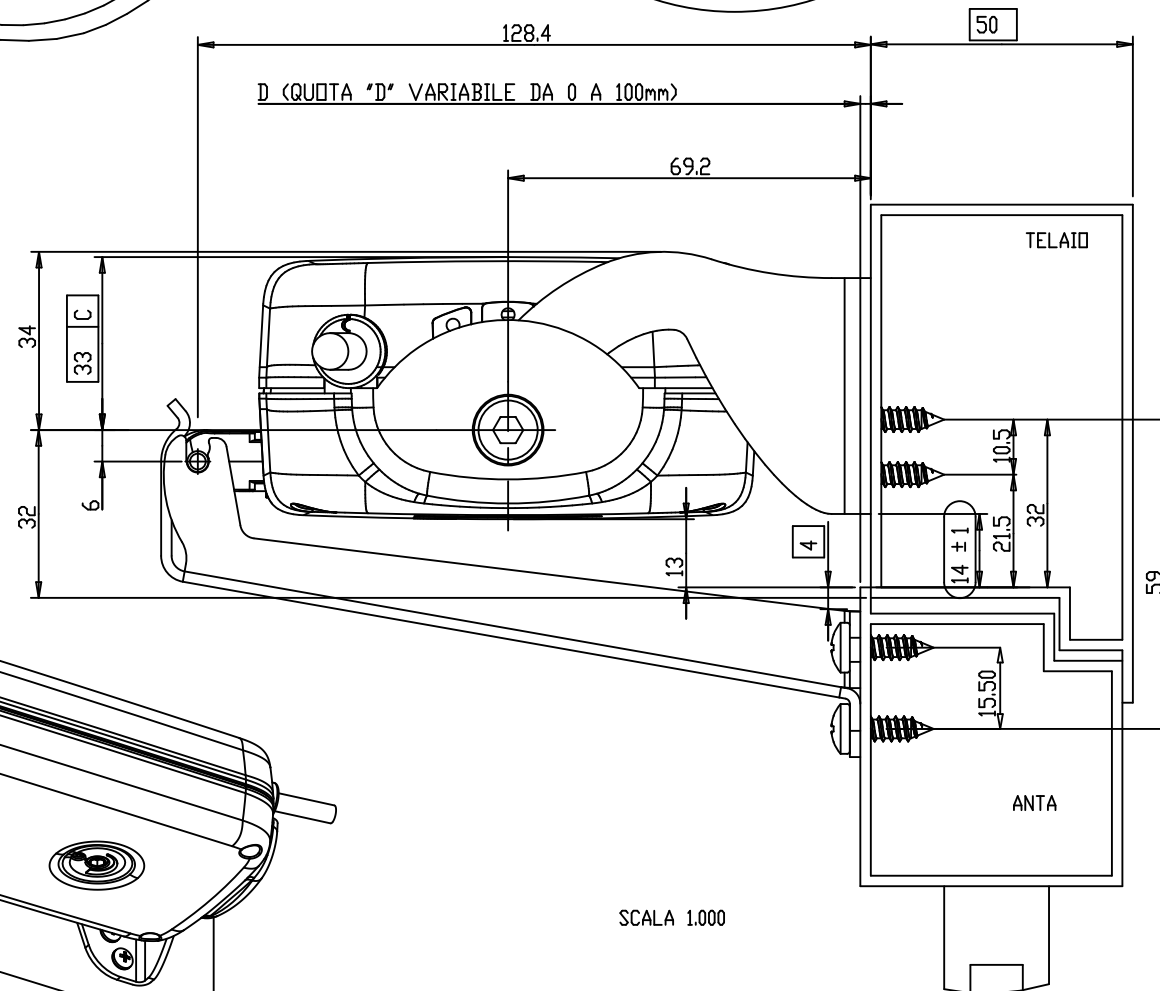
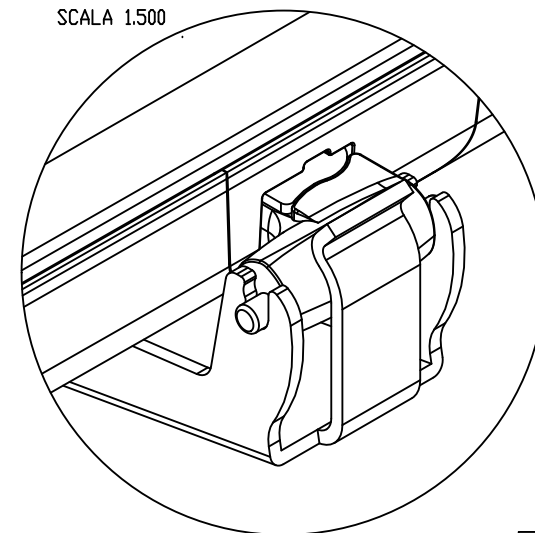

SCALA 0.500

POSIZIONE POSITION	CORSA (A) STROKE (A)	LUCE MIN. FINESTRA (B) MIN. WINDOW LENGTH (B)	INGOMBRO MOTORE (C) OVERALL DIMENSION OF MOTOR (C)
1	100mm	300mm	41mm
2	150mm	300mm	45mm
3	200mm	300mm	48mm
4	250mm	400mm	49mm
5	300mm	500mm	48mm
6	400mm	900mm	42.5mm
7	500mm	1000mm	43mm

**TOPP**  
tecnologie del movimento

Disegnato/Drafted: TOPP SRL  
Data/Date: 01/01/16

Denominazione/Description:  
C40 APPLICAZIONE VASISTAS  
C40 BOTTOM HUNG WINDOW APPLICATION

Formato/Format: A2    Scala/Scale:    Proiezione/Projection:    Codice/Code: EA2013    Rev: 01    Data/Date: 01/01/16

La proprietà del disegno e/o del progetto suindicato è della Topp s.r.l. spetta alla Topp s.r.l. la facoltà di riprodurre o far riprodurre il disegno e/o il progetto in ogni sua forma. L'utilizzatore si impegna a non divulgare e riprodurre in ogni sua forma il disegno e/o il progetto di proprietà della Topp s.r.l. di cui in suo possesso e ad utilizzarlo per le finalità espressamente indicate dalla proprietà. The property of the draft and/or the project is of the Topp s.r.l. the faculty is up to the Topp s.r.l. to reproduce or to make to reproduce the draft and/or the project. The reader is engaged to not to disclose and to reproduce, in every way, the design and/or the project of property of the Topp s.r.l. of which in its possession and using it for the purposes express indicated from the property.